



FEATURES

- Oil lubricated rotary vane vacuum pump, nominal speed 25 m³/h;
- Vacuum level control through high precision sensor;
- Maximum vacuum 99,95% (0,5 millibar);
- Front 455 mm sealing bar, easily removable for cleaning;
- Removable sealing bar lifting device, with sealing cap for cleaning;
- Standard inert gas injection with 2 injection nozzles (or 2+2 or 3+3 nozzles according to the double sealing bar option);
- Digital control panel with 6 keys and 6 digit display;
- 10 editable programs;
- Program for vacuum packaging in containers;
- Adjustable sealing intensity;
- Pump oil dehumidification program "H2Out";
- Resettable oil change alarm;
- Analog vacuum gauge for displaying the vacuum level;
- AISI304 Stainless steel vacuum chamber with 2,5mm constant thickness;
- AISI304 stainless steel machine body with easily accessible pump oil drain;
- High-thickness PMMA (Plexiglass) lid with polished and rounded edges; opens automatically at the end of the cycle;
- Chromed aluminum die-cast hinges;
- Thermal welding protection system;
- 3 PE-filling plates for product adjustment and cycle speed up

DESCRIPTION

Levac C46 is a table top model made entirely of AISI304 stainless steel, equipped with a 25m³/h pump, with digital control panel, vacuum sensor, standard inert gas injection, equippable with double sealing bar. It is characterized by extreme robustness, ease of use and attention to detail. The standard of quality and reliability of the packaging machine and its components is the result of over twenty years of presence and wide diffusion on the global market of this model, in all areas and in all sectors.



SEALING BAR 455-520 mm
VACUUM PUMP 25 m³/h
SENSOR CONTROL

OPTIONALS

- Double 455mm or 520mm sealing bars;
- "Easy" - accessory for external vacuum in embossed bags

ACCESSORIES

- Bags for storage, cooking and "cook & chill"; embossed bags;
- Inclined stainless steel plate for liquid packing



PROJECT	DATE	APPROVED
ITEM	QTY	

VACUUM PACKAGING MACHINES LEVAC C46

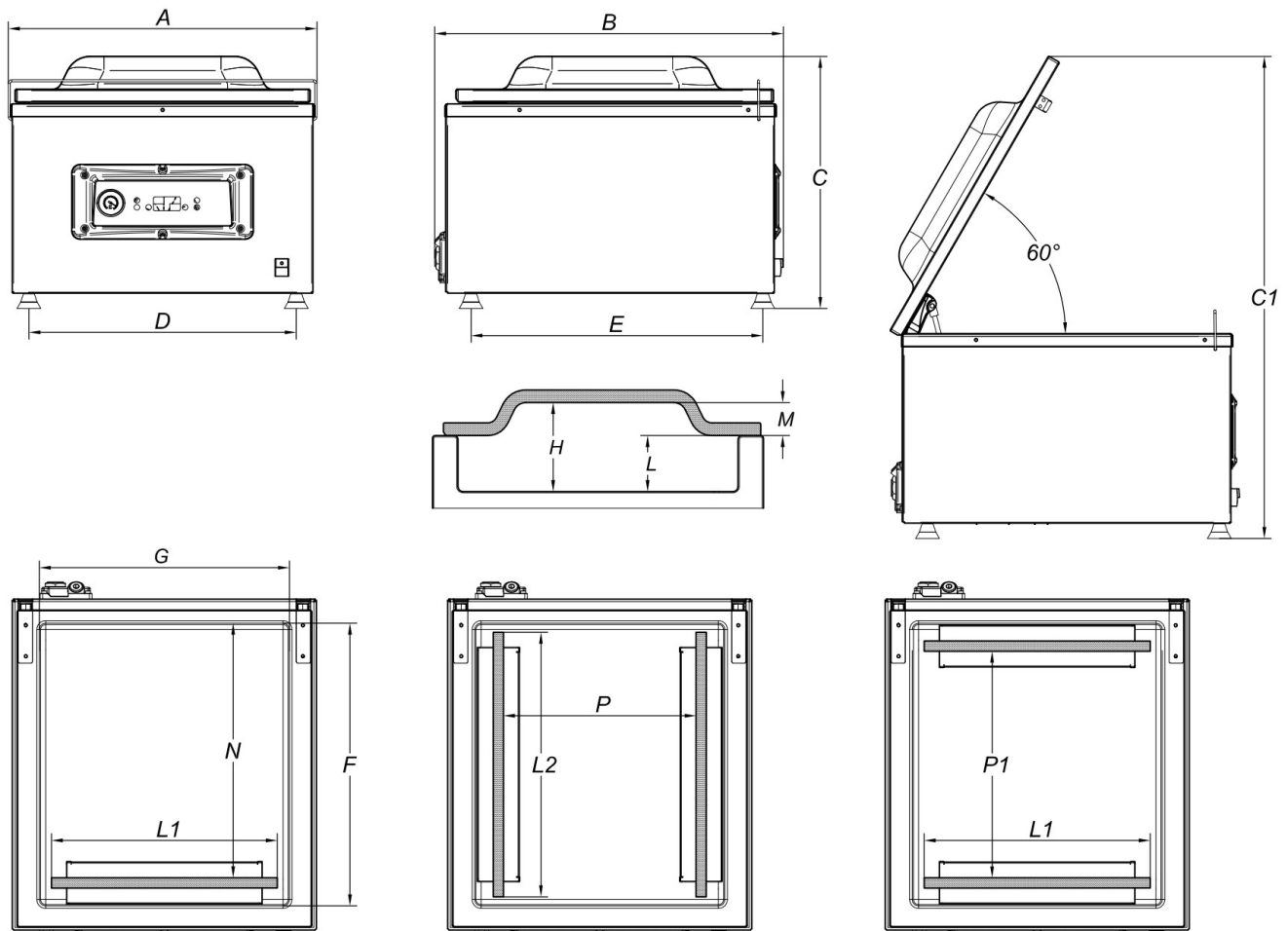

SPECIFICATIONS

Length of seal L1	mm	455
Length Of Seal L2	mm	520
Nominal pump speed	m ³ /h	25
Final pressure	mbar	0,5
Chamber Size (FxGxH)	mm	556x492x175
Useful space Chamber (N)	mm	500
Useful space Chamber (P1)	mm	446
Useful space Chamber (P)	mm	380
Chamber depth (L)	mm	110
Chamber volume	Lt	37,5
Power	W	1200
Electrical voltage/Frequency/Phases	V/Hz	220-240V / 50-60Hz / 1Ph+N+PE
Power cord and plug		3m / Schuko
Current	A	5,2
Housing materials		Stainless steel (AISI304)
Vacuum chamber material		Stainless steel (AISI304)
Lid material		PMMA (plexiglas)
Overall dimensions (AxBxC)	mm	607x686x496
Maximum height with open lid (C1)	mm	948
Distance between supports (DxE)	mm	526x574
Weight (with shelves)	kg	97
Noise level	dB(A)	57
Environmental operating temperature (min-max)	°C	12-40