

AUDION
Packaging Machines



SPEEDPACK PACKAGING SOLUTIONS

-400 SERIES-



*Ultimate flexibility
in bag packaging
Maximum productivity
and efficiency*



Together we make the perfect package.



SPEEDPACK PACKAGING SOLUTIONS

The Speedpack Hybrid is a state-of-the-art poly bag packaging solution for process automation. This system can be tailored to a specific application, to create the perfect package in any market. This revolutionary compact packaging machine can operate from both lay flat tubing and pre-made bags on roll. This dual application proves to be a distinctive advantage when compared to traditional bags on roll machines, generating savings (film usage, material cost, changeover).

The Speedpack Hybrid shines when it comes to **flexibility** and **user friendliness**:

from the user-friendly touchscreen interface to various settings that can be activated as well selecting the desired bag length for the product being packaged.

Over the years Speedpack has proven to be the high-end packaging solution for many warehouses, creating greater efficiency and a proven short return on investment.

Discover our tailored product solutions for every market

SPECIFICATIONS SPEEDPACK 400 / 400 SPKH

BENEFITS

- Works from both lay flat tubing and pre-opened bags on roll
- Ceramic sealbar for accurate sealing temperature and quick start-up time
- Flexible bag length selection for material cost savings
- High-end components and most advanced technology integrated
- User-friendly touchscreen guarantees ultimate flexibility in product settings
- Built-in interface ports facilitate communication with feeding and discharge systems
- Communication to various coding, labeling, and printing systems
- Compact size takes up minimal footprint
- Quick film changeover
- Automatic cycle mode and batch counter
- Machine on caster wheels for more flexibility
- Different working heights available
- Self-diagnostic function for quick troubleshooting
- Numerous tailored product solutions available!

VALUE

- Simplify your warehouse packaging process
- Generate considerable labor-savings
- Reduce your film usage by right-sizing to the product being packaged
- Maximize flexibility with quick changeover for different bag sizes
- Increase capacity during peak workload
- Ensure a worry-free packaging process

TECHNICAL SPECIFICATIONS

- Seal width: 1,5 mm (optional: 3 mm or 8 mm impulse seal)
- Film material: suitable for PE, CPP and laminates (optionally Tyvek and medical paper possible)
- Film thickness: (min-max) 40-125 micron
- Max. film roll width: 400 mm
- Max. film roll diameter: 360 mm
- Max. packaging capacity lay flat tubing: 15 - 20 bags / minute *
- Max. packaging capacity bags on roll: 60 bags / minute *
- Min. bag size: 80 mm width x 80 mm length (smaller bags on request) **
- Max. bag size: 400 width x 600 mm length **
- Max opening between seal bars: 150 mm
- Dimensions (L x W x H): 1100 x 845 x 1100 mm
- Power supply: 230 V-1 ph-50/60 Hz (1850 Watt)
- Required compressed air connection: 6 Bar, 200-500 NL/min
- IP rating: IP20
- Low Voltage Directive: EMC Directive, Standards 2006/95/EC, 2004/108/EC, EN-150-12100

- * depending on options configured at machine, bag size, gauge, material and product
- ** for smaller bag lengths some options may not be suitable, longer bag lengths (>600) possible by adding special options

Discover our tailored product solutions for every market!

EXTRA SPEEDPACK VERSIONS

Besides the popularity of Speedpack Hybrid, creating the extra value of material savings by packing your product in a well-fit bag. Speedpack is also available in other versions: For warehouses using wider films up to 550 mm the **Speedpack 550** offers a very advanced packaging solution.

Besides these hybrid Speedpack models Audion has also developed special Speedpack versions operating exclusively bags on roll: the compact **Speedpack 300 bagger** and the **Speedpack Bags on roll or Fan-folded Bags version**. These models stand out because of their higher production speed and short-bag options.

SPEEDPACK 300 TABLETOP

A smart, tabletop, semi-automatic bagger operating from pre-opened bags on roll (max. 300 mm bag width). This cost-effective solution for warehouse packaging is electrically powered (no compressed air needed) and can be easily plugged in for packaging a wide variety of products in production lines.

Max. film roll width: 300 mm
Max. capacity (bags on roll): up to 20 bags/minute*
Min./Max. bag width: 50 - 300 mm
Min./Max. bag length: 90 - 500 mm
No compressed air requirement, electrically driven



Scan me



SPEEDPACK FOR PRE-OPENED BAGS ON ROLL/FAN-FOLDED BAGS FROM BOX

For customers operating pre-opened bags on roll only, Audion also designed a Speedpack for operating exclusively pre-opened bags on roll or fan-folded bags from a box (no bag creation assembly integrated).



Scan me



SPEEDPACK HYBRID 550

The Speedpack Hybrid 550 has been developed for operating lay flat tubing and pre-opened bags on roll with a maximum width of 550 mm. Speedpack 550 enables a wide opening of the sealbars of maximum 260 mm. An advanced technology enables electric adjustment of frame height. Further, the Speedpack 550 can be equipped with various advanced features tailored to any customer, such as automatic adjustment of bag support for various bag lengths, coding solutions, product discharge solutions.

Max. film roll width : 550 mm
Max. capacity (lay flat tubing) : 16 bags/minute*
Max. capacity (bags on roll) : up to 40 bags/minute*
Min. bag size : 130 mm (W) x 130 mm (L)
Max. bag size : 550 mm (W) x 900 mm (L)
Sealbar opening : 260 mm
Air requirement : 6 Bar

*depending on bag size, material, printing and operator



Scan me



OPERATING SOLUTIONS

Some examples to tailor Speedpack Hybrid for maximum user efficiency (more solutions are available)

PRODUCT DETECTION SENSOR

This sensor activates the sealing when a product is detected in the bag.



FOOTSWITCH

A footswitch will allow the operator to have both hands free while filling the bag.



HAND ACTIVATION SENSOR

This sensor detects the presence of the operator's hand above the loading area. Once the operator drops in the product and removes his hand from the loading area then the machine automatically starts the cycle. This solution eliminates a step in the packaging process, as the operator does not need to press a button or footswitch for activation.



OPERATION PANEL ON ARM

The touch panel can be fixed at an extended arm. In combination with some feeding systems this option is recommended in order to operate the machine easily.



AUDION TOUCHSCREEN (STANDARD)

All settings and solutions for Speedpack Hybrid can easily be controlled from the user-friendly Audion touchscreen. Switching on/off specific film solutions when changing to different products, manual or automatic cycling, storing recipes, adjusting seal parameters and more: all your product solutions can easily be controlled from this advanced touch screen to optimize productivity of your Speedpack Hybrid.



HEAVY PRODUCT SOLUTIONS

Heavy or odd products need special care for product support or bag opening. Speedpack Hybrid offers various solutions:

INCLINABLE SUPPORT TABLE

For bag support during filling & sealing various support tables are available (standard support table, extra long support table for longer bags or support table including lift and vibration to compact a product). At the end of the cycle the support plate is tilted at an angle, dispensing the bag.



BAG SUPPORT DISCHARGE CONVEYOR

This conveyor can be lifted to support the bag during sealing. After sealing the bag will be discharged by the conveyor.



BAG STRETCHER

To stretch the bag during sealing to minimize wrinkles. Shown: bag in open position before bag is stretched for sealing.



EASY LOAD BAG OPENER / HEAVY PRODUCT CLAMPS

Easy opening & loading system, recommended for supporting heavier products and opening of wide size films. This system creates a square or rectangular opening for easy loading of product. Also, the film is gripped by the system for extra support of heavier products. Finally the film is stretched by the bag stretcher which is automatically included in this feature. All features in one solution!



BAG PRESENTATION SOLUTIONS

To enable maximum flexibility in bag presentation. More solutions available

PRE-PRINTED FILM

In order to let your Speedpack Hybrid operate from your own pre-printed film a sensor can be installed to detect the print mark.



CHAIN BAGS WITH PERFORATION

A strip of bags can be made for packing different parts separately in one chain of film. (different bag lengths possible)



HEADER WITH HANG HOLE

An extra seal and hang hole near the top of the bag to allow a package to be placed on a retail display hook.



CUSTOMIZED FILM SOLUTIONS

Some products require extra solutions for film application. Speedpack Hybrid offers several options. Some examples are:

EASY BAG OPENING

A tear notch or horizontal perforation over the complete bag can be created for easy opening of the bag.



AIR REMOVAL

Several solutions are available for removing air from the bag.

- Air press device - Ventilation hole - Film perforator (on request only)



FILM END DETECTION

This sensor detects when the film roll is empty and stops the Speedpack to allow a changeover of the film roll.



FILM GUIDE

To assure the film is properly guided through the machine (ideal for narrow film or some special engineering solutions).



BAGS ON ROLL SENSOR

When you prefer to use pre-opened bags on roll an extra sensor can be installed for accurate film transport.

PRODUCT FEEDING LOADING/SOLUTIONS

Speedpack Hybrid can easily be integrated with (automatic) feeding or loading systems for optimizing your productivity. Some examples are:

FUNNEL SYSTEMS

Various stainless steel funnel systems (with or without accumulating function) can be mounted to load your product into the bag.



OPTIMIZER CONVEYOR TABLE

A sorting table with integrated conveyor including divider sections to prepare single products or kits for feeding into the Speedpack Hybrid.



SORTING TABLES

Various sorting tables are available for preparing your products before being loaded into the bag.



HANDSHAKE

An interface port and synchronization cable will allow the Speedpack Hybrid to communicate with external dosing systems.



BAG OPEN SENSOR

This sensor detects if the bag is well positioned for automatic feeding. It prevents the product from falling on the floor when the bag is not ready yet.



ROBOTIC (out) FEEDING

A special handshake will allow Speedpack Hybrid to communicate with robotic arms, which facilitate the filled bag being taken from the Speedpack.

WEIGHING & COUNTING SOLUTIONS

Speedpack Hybrid offers several state-of-the-art solutions for packaging the desired quantity or weight per bag. Some examples are:

COUNTING SYSTEM INCL. REJECT FUNCTION

This counting system can be integrated to create an extremely accurate automatic bulk counting and bagging system for packaging small parts.



Play video

PRODUCT DISCHARGE SOLUTIONS

For generating maximum efficiency in your production line Speedpack can be connected to various types of discharge solutions.

BAG SUPPORT DISCHARGE CONVEYOR

This conveyor supports the bag during sealing after which the bag is automatically discharged.



TABLE OPTIWEIGH COUNTER

A smart preparation table with integrated bucket weigher which automatically drops the product load into the bag once the weight is reached.



Play Video

OUTFEED CONVEYOR:

The outfeed conveyor automatically transports the bags from the Speedpack up to table height or a transport container. Various models available.



PRINTING SOLUTIONS

Unique coding, batch coding, next-bag-out coding or labeling. Speedpack Hybrid communicates with various printers and label applicators that can be mounted and integrated in your data network. Some examples are:



LABEL PRINTER APPLICATORS

Various integrated label printer applicators are available for printing and applying a label directly on the outside of the bag, depending customer requirements (batch or next-bag-out production).



Watch video

THERMAL TRANSFER PRINTERS

Superior coding solution for printing variable data like expiry dates, barcodes, customer addresses etc. directly onto the film. Our printers are available in various print widths to accommodate different printing requirements.



Scan me

SAFETY SOLUTIONS

Speedpack Hybrid fully complies the EC safety directives. Sealbars are closing under low pressure, to ensure safety. For additional operator safety we have developed extra solutions.

EXTERNAL EMERGENCY CIRCUIT

Safety system will be integrated in an external safety system, which would be the master of the circuit. Reset of the circuit can only be done after the master has been reset.

DATA COMMUNICATION SOLUTIONS

Various communication solutions are available to integrate Speedpack Hybrid into a network or facilitate communication to infeed or outfeed systems. Speedpack will be able to communicate with coding systems, ERP systems and feeding systems to generate maximum efficiency.

HANDSHAKE

An interface port and synchronization cable will allow the Speedpack Hybrid to communicate with external dosing systems.



TWO HAND ACTIVATION

Two buttons that must be pushed simultaneously in order for the Speedpack to cycle. This ensures hands will not be in the seal area during cycling.



SAFETY LIGHT CURTAIN

An extra feature for maximum operation safety. Prevents the operation of the Speedpack Hybrid when the optical detection field is obstructed.

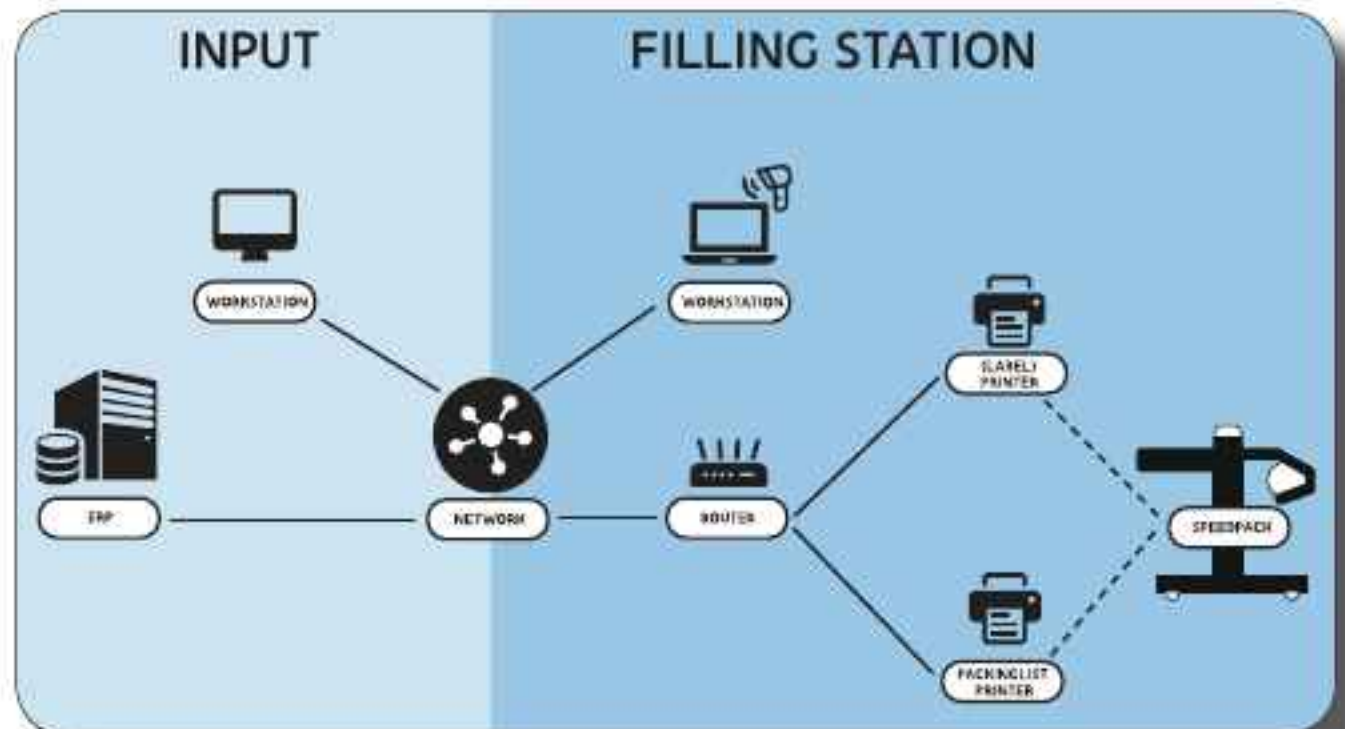

EXTRA SOLUTIONS

Many extra solutions are available for tailoring Speedpack Hybrid to the most efficient operation mode for every market, for more solutions contact Audion, audion.com



Traffic light warning

Visual indicator of current operating status of the bagger (red for a stop, yellow for caution, green for operation).



WINDOW SENSOR

The window sensor detects and counts your products. The machine cycle is activated automatically when the pre-set count has been reached.



ELEVATED MACHINE FRAME

The frame of Speedpack can be elevated when operating with longer bags (>600 mm) or for optimizing your production area.

CONTACT AUDION FOR MORE SOLUTIONS

Many extra solutions are available for tailoring your Speedpack Hybrid to the most efficient operation mode for every market. No packaging lines are the same. That is why we have designed our Speedpack Hybrid as an incredibly flexible packaging machine.

The R&D department in our production plant in Kleve (Germany) consists of a team of dedicated and experienced engineers adopting each packaging problem as their challenge, to create the perfect package together. We kindly invite you to contact Audion if you are looking for a partner who can identify new solutions for your packaging problem!

Together we make the perfect package.



DIMENSIONS SPEEDPACK HYBRID 400

Speedpack Hybrid 400 features a compact design, taking up minimal footprint.

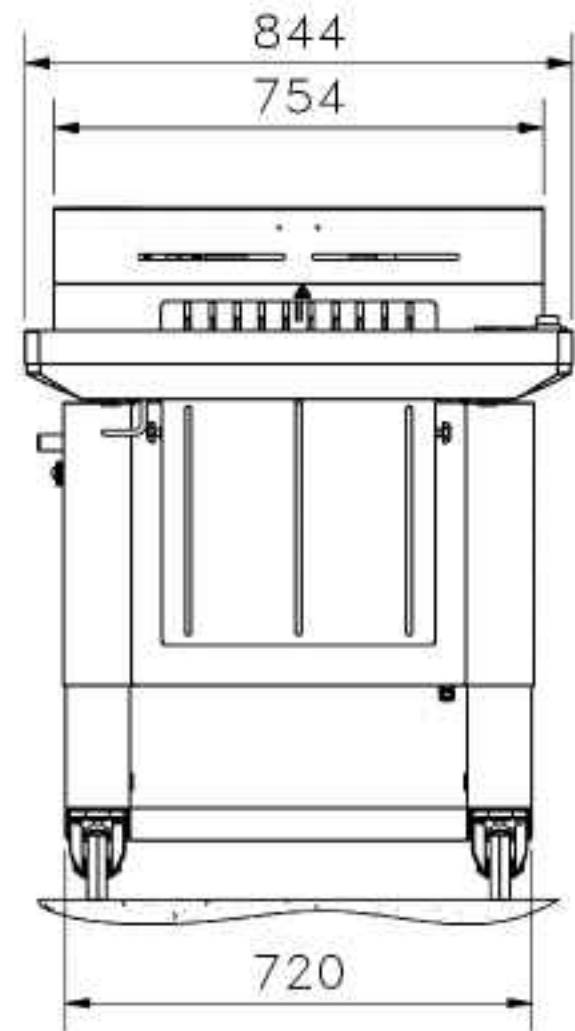
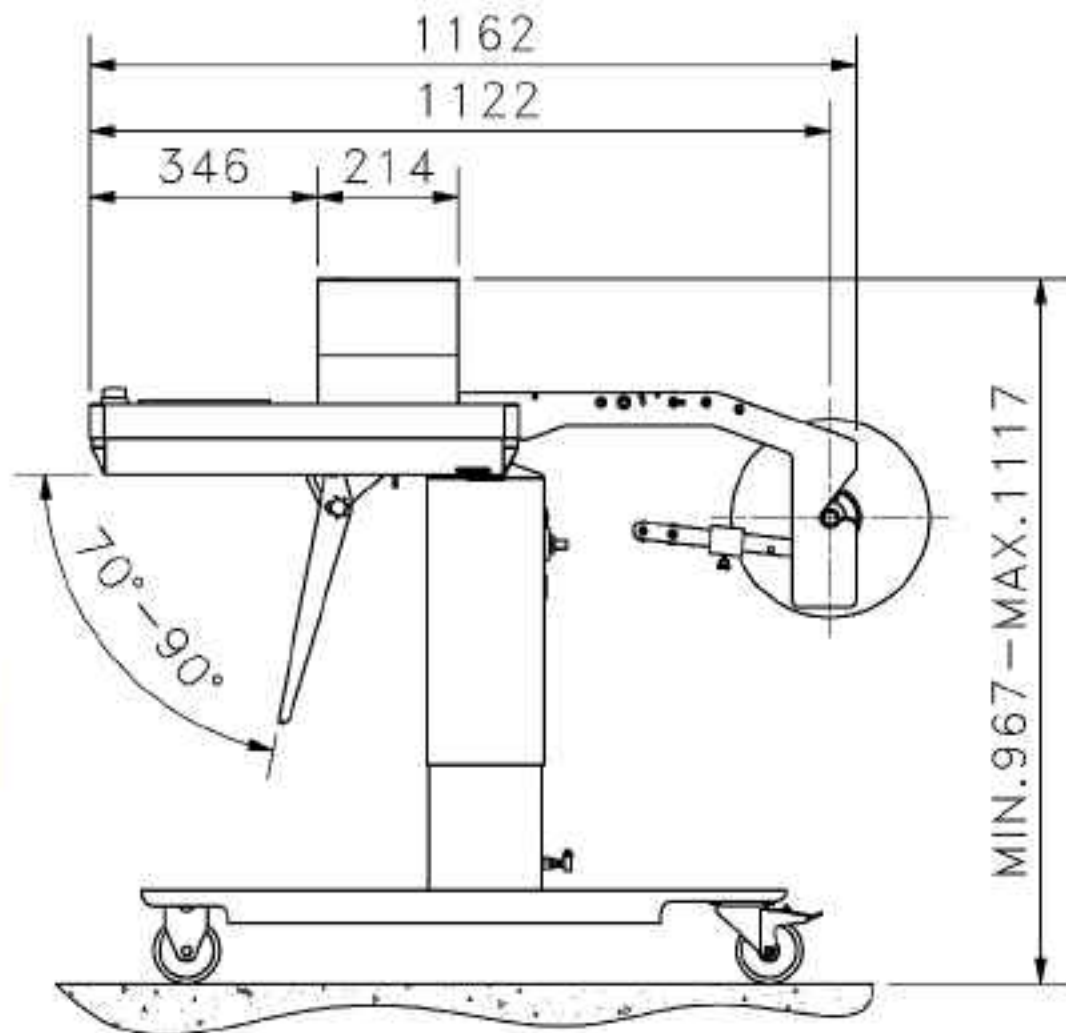

CUSTOM ENGINEERING

Every packaging line has its unique requirements. Audion can develop a tailored Speedpack to optimize any packaging environment.



Speedpack Hybrid for counting & packaging parts



*Speedpack Hybrid for counting & packaging parts
by a window sensor*



*Speedpack Hybrid for packaging medicines
in order fulfillment*



*Speedpack Hybrid for
packaging parts in longer bags*

AUDION R&D



Our internal R&D enables us to stay on top of trends and latest innovations in the market. We not only provide you with the best products in the industry but we also take care of the service and maintenance which makes us a full service provider.

Every market, from industrial to retail, standard or custom made, we develop a solution for your packaging challenges. Not only for today, but also for the future.

Together we make the perfect package

SPECIAL MARKETS

Either integrated in production lines or stand-alone operation, implementing the Speedpack Hybrid will streamline your packaging operation and create a considerable improve in efficiency for many markets. Using advanced technology, in-house R&D, and high-end components, the Speedpack has been designed as a versatile packaging machine offering maximum flexibility and reliability for many markets. Some markets require specific packaging applications. Speedpack delivers a **full and flexible packaging solution for any market**, tailored to your own specific product requirements.



SPEEDPACK HYBRID MEDICAL/PHARMACEUTICAL

The packaging of medical instruments, medicines, test material for laboratories or other medically related products requires extra care on hygiene and safety. Special safety and hygiene solutions have been developed to meet the strict requirements for precise medical or pharmaceutical packaging.

- *Validatable sealing system*
- *Running sterilizable packaging films (Tyvek, medical peelable paper laminate)*
- *Extra wide seals*
- *Cleanroom packaging*



SPEEDPACK HYBRID ORDER FULFILLMENT / E-COMMERCE BAGGING

A complete bagging system for e-commerce packaging and order fulfillment saving material! This bagging system has been designed to meet the high requirements in order accuracy, cost efficient production, minimizing human intervention. Solutions included:

- *bag size selection for every order*
- *a printer / labeler (next-bag-out)*
- *product support discharge*



Watch video



SPEEDPACK HYBRID PARTS PACKAGING

All kinds of free flowing parts have to be packed. From small production lines to large fully automated production areas: Speedpack Hybrid allows full accuracy in counting, weighing, filling and labelling.

- *feeding solutions*
- *coding solutions*
- *weighing & counting solutions*
- *discharge solutions*



Scan me

By implementing the Speedpack Hybrid into your warehouse a state-of-the-art flexible packaging technology is implemented, offering opportunities for more production increase and material savings.

We kindly invite you to contact Audion for exploring various Speedpack (Hybrid) versions tailored to your business!

audion.com/speedpack

 **AUDION**
Packaging Machines

Together we make the perfect package.



**SPEEDPACK
PACKAGING
SOLUTIONS**